

**III MULTISTACK®**

# MSRW MINI SERIES

**Modular Water Cooled Scroll Chiller**

MSRW075  
Nominal Capacity 71 to 1136 kW(R)





# Contents

<b>DESIGN FEATURES</b>	<b>1</b>
<b>C1 CONTROL</b>	<b>4</b>
<b>PHYSICAL DATA</b>	<b>5</b>
<b>UNIT CAPACITY</b>	<b>7</b>
<b>CHILLER SELECTION</b>	<b>8</b>
<b>FIELD WIRING DIAGRAM</b>	<b>9</b>
<b>CHILLED WATER PIPING INSTALLATION</b>	<b>10</b>
<b>LOW TEMPERATURE COOLING</b>	<b>11</b>
<b>PHYSICAL DIMENSIONS</b>	<b>12</b>
<b>ELECTRICAL DATA PER MODULE</b>	<b>13</b>

# Design Features

## FLEXIBILITY IN DESIGN

A Multistack chiller is a bank of individual chiller modules connected in parallel to operate as a single machine. Each SRW 075 & 085 module contains two completely independent refrigeration circuits. Cooling capacity is matched to load demand by varying the number of refrigeration circuits in operation.

## COMPACT AND SPACE-SAVING

With each module approximately 550mm wide, you can install these quiet, compact units in small and confined spaces. In new buildings, you can reduce the size of plant rooms and save on structural costs.

## LOWER INSTALLATION COST

The compact size of each chiller module means easy access via standard lifts and standard doorways. You don't need expensive cranes or special rigging.

Connecting the modules is simple - you only have four pipes. An active link connects electrical power. Clip in the control connections and you're in business. Fast.

## ADD-ON FLEXIBILITY

As your needs for cooling increases, Multistack has the solution. Being a modular chiller, it has never been easier to expand the system as larger cooling capacity is needed to meet increased building load demands, with no complicated changes to the room, piping system or control system, and all work can be done quite easily.

As many as 16 modules can be connected together as a chiller bank, producing a total of 1168kW / 1312kW for the SRA075 and SRA 085 respectively. The Multistack miniseries range has inbuilt flexibility, useful in tenancy changes and strata title applications.

## SAFE AND RELIABLE

Every module works as an independent refrigeration circuit, with adjacent modules operating independently. In the event of a malfunction in the system, the computer selects the next available standby module to provide back up. One failed module will not disrupt the rest of the system, giving you total piece of mind.

## EFFICIENCY CURVE AT PART LOAD (R22)

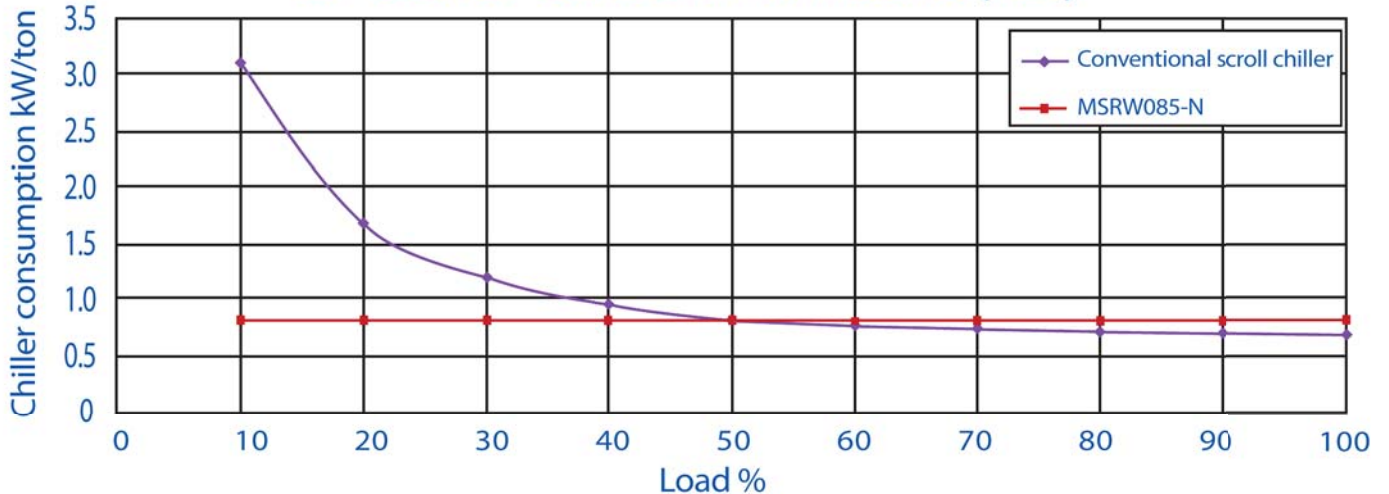

## PEAK ECONOMY AT ALL LOADS

Automatic scheduling of the chiller's compressors allows Multistack to match the fluctuating cooling load and conserve energy with each unit running at its peak economy. The bottom line is lower cost per rentable sq. metre.

## HIGH EFFICIENCY, QUIET OPERATING SCROLL COMPRESSOR. GIVING YOU OUTSTANDING RELIABILITY & PERFORMANCE

Our compressors have a high coefficient of performance (COP) – (approximately 9% higher than that of a reciprocating compressor), resulting in outstanding reliability due to fewer moving parts, lower starting torque, and tolerance for flood-back and a rigid internal construction. All this is achieved through high volumetric efficiency, minimized pressure losses due to the absence of valve plates, and reduced heat transfer loss due to better separation of suction and discharge gases. In addition, scroll compressors produce less vibrations and quieter than that of its hermetic counterpart (due to absence of dynamic suction and discharge valves and a much smoother compression process).

## FILTRATION

The strainers in the condenser water circuit are an integral part of the chiller. They are fitted inside the water distribution header before the heat exchanger. The developed area of the filter is large and therefore only creates an initial clean filter pressure drop of 5 kPa. This is an economical in-line filter solution providing good filtration with a No. 60 mesh screen. These filters are 316 stainless steel and can be easily removed for cleaning purposes.

## UNCOMPLICATED OPERATION

All systems in the chiller are controlled by the dedicated computer which records and displays the operating parameters of the chiller bank in plain English (other languages are also available).

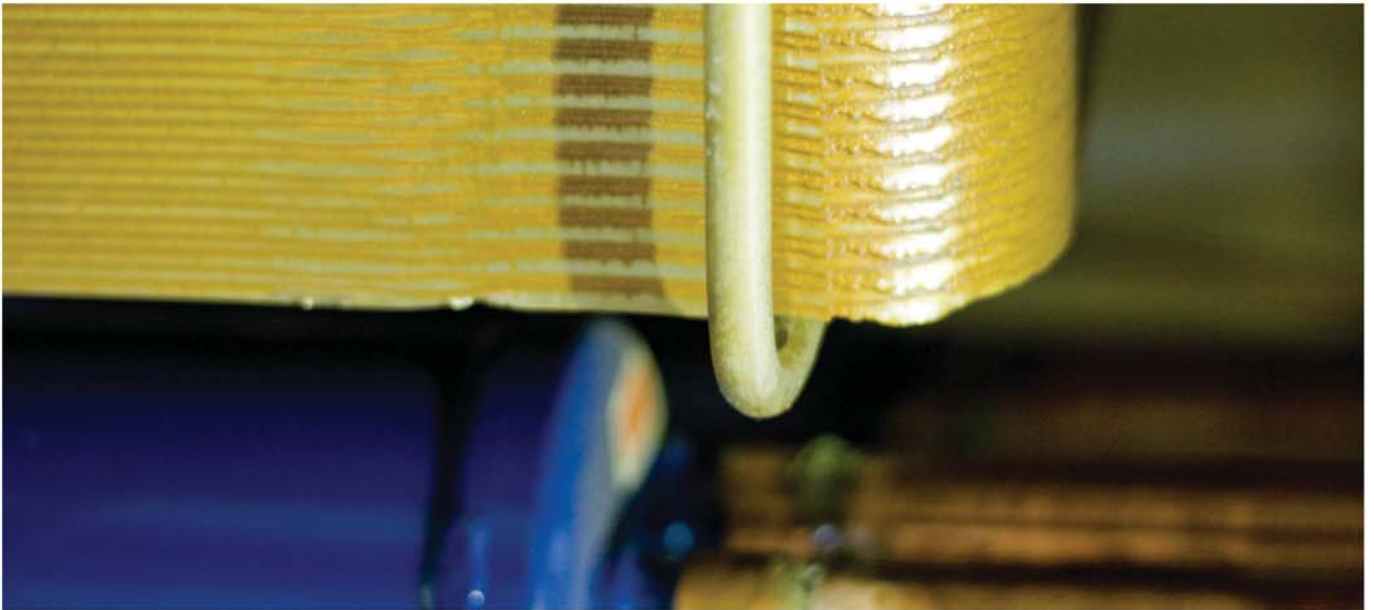

## UNPARALLELED DEPENDABILITY

Each slave module is identical to each other therefore, In the event of a malfunction in the refrigeration circuit; the computer selects the next available standby module to provide back up.

For critical air conditioning and industrial process cooling a Multistack modular chiller inherently provides economical standby capacity and unparalleled dependability.

The use of standard components in our chillers also enhances system reliability.

## ENVIRONMENT FRIENDLY

Multistack Chillers are friendly to the environment, and currently running on the non-toxic R22 refrigerant (approved under the Montreal Protocol, and for sale until 2030) as standard, along with the R407c and R134a as optional. It is also pleasing to the ears, running quietly even at 100% capacity.

## Model Number Designation

M	SR	W	075		-	6	A		F	
1	2	3	4	5		6	7	8	9	10

1. Modular series
2. Scroll compressor
3. Cooling type  
A: Air-cooled  
W: Water-cooled
4. Model type
5. C: Colling Only  
H: Heat Pump

6. Number of Modules  
No. of modules per Chiller (1-16)
7. Electrical Specifications  
A: AC380-420V/50Hz/3Ph  
B: AC380V / 60Hz / 3Ph  
C: AC440-460V/60Hz/3Ph
8. Configuration:  
- Blank for Standard

- 9: Refrigerant  
E: R134a  
F: R22  
R: 407c
10. Upgrade

# Computer Control System 'C1'

## COMPUTER CONTROL

A computer control and monitoring system runs the Multistack chiller bank and schedules each compressor on or off, depending on the changing cooling load.

With the optional Multistack Remote Control Monitoring software, the user is able to monitor the status of the chiller remotely.

## SYSTEM WATER FLOWS

The computer will stop the chiller from operating if the water flow through the condenser circuit or evaporator circuit falls below the limit setting of the flow switches. This condition is monitored via flow switches and water pump interlock contacts (provided by installing contractor).

## TEMPERATURE CONTROL

By monitoring the entering chilled water temperature, optimal control of the leaving chilled water temperature is maintained. The accuracy of temperature control increases with the number of capacity steps. Integrated temperature calculation ensures reduced running costs.

## COMPRESSOR SEQUENCE

At re-start or re-loading of the chiller the next compressor with minimum running time is selected as the lead compressor. If a compressor stops on a safety protection interlock, the next compressor in line will be selected.

## COMPRESSOR LIMIT START TIMER

The computer has an adjustable ramp-on timer in addition to the inbuilt 4 minute stop-to-start delay of each compressor to prevent rapid cycling.

## FAULT REPORT

The last recorded fault is displayed in conjunction with a built-in buzzer alarm.

## SAFETY PROTECTION FEATURES

High/Low pressure cut out

Thermistor module for compressor motor windings temperature protection

Low leaving chilled water temperature cut out for each slave and system

Low refrigerant suction pressure cut out for each slave



# Physical Data Per Module

Model		MSRW 075		
Cooling	Refrigerant Type	<b>R22</b>	<b>R407c</b>	<b>R134a</b>
	Nominal Cooling Capacity (kW)	71.0	69.5	47.3
	Compressor Power Input (kW)	15.2	15.8	11.2
Compressor	Type	Scroll Hermetically Sealed		
	Number	2		
	Power	380-420V / 50Hz / 3 Phase		
	Max. Rated Current (A)	26 x 2	29 x 2	
	Locked Rotor Amperage (A)	147 x 2	145 x 2	
	Rating Load Amperage (A)	19.3 x 2	22.9 x 2	
	Control Stages	0, 50%, 100%		
Refrigerant	Charge (kg)	3.8 x 2	3.6 x 2	3.7 x 2
Evaporator	Type	Brazen Plate Heat Exchanger		
	Water Flow Rate (L/s)	3.39	3.32	2.26
	Water Pressure Drop (kPa)	35		
	Fouling Factor (m <sup>2</sup> k/kW)	0.018		
	Max Working Press.(Refrigerant Side) (kPa)	2400		
	Max Working Press.(Water Side) (kPa)	2000		
	Pipe Connection	6"		
Condenser	Type	Brazen Plate Heat Exchanger		
	Water Flow Rate (L/s)	4.12	4.08	2.80
	Water Pressure Drop (kPa)	35		
	Fouling Factor (m <sup>2</sup> k/kW)	0.04		
	Max Working Press.(Refrigerant Side) (kPa)	2400		
	Max Working Press.(Water Side) (kPa)	2000		
	Pipe Connection	6"		
Dimension (L x W x H) mm		1250 x 550 x 1622		
Operation Weight (kg)		510	530	530
Shipping Weight (kg)		460	480	480

Nominal Values based on:

- Chilled Water Leaving Temp. 7°C
- Chilled Water Entering Temp. 12°C
- Condenser Water Leaving Temp. 35°C
- Condenser Water Entering Temp. 30°C

**Note:** Minimum Chilled Water Flow per module: Nominal Water flow Rate less 10%  
 Minimum Condenser Water Flow per module: Nominal Water flow Rate less 10%

Contact nearest authorized agent if lower flow rate is required.

# HEAT EXCHANGER WATER PRESSURE DROP

Pressure drop correction factor for chilled and condenser water circuit

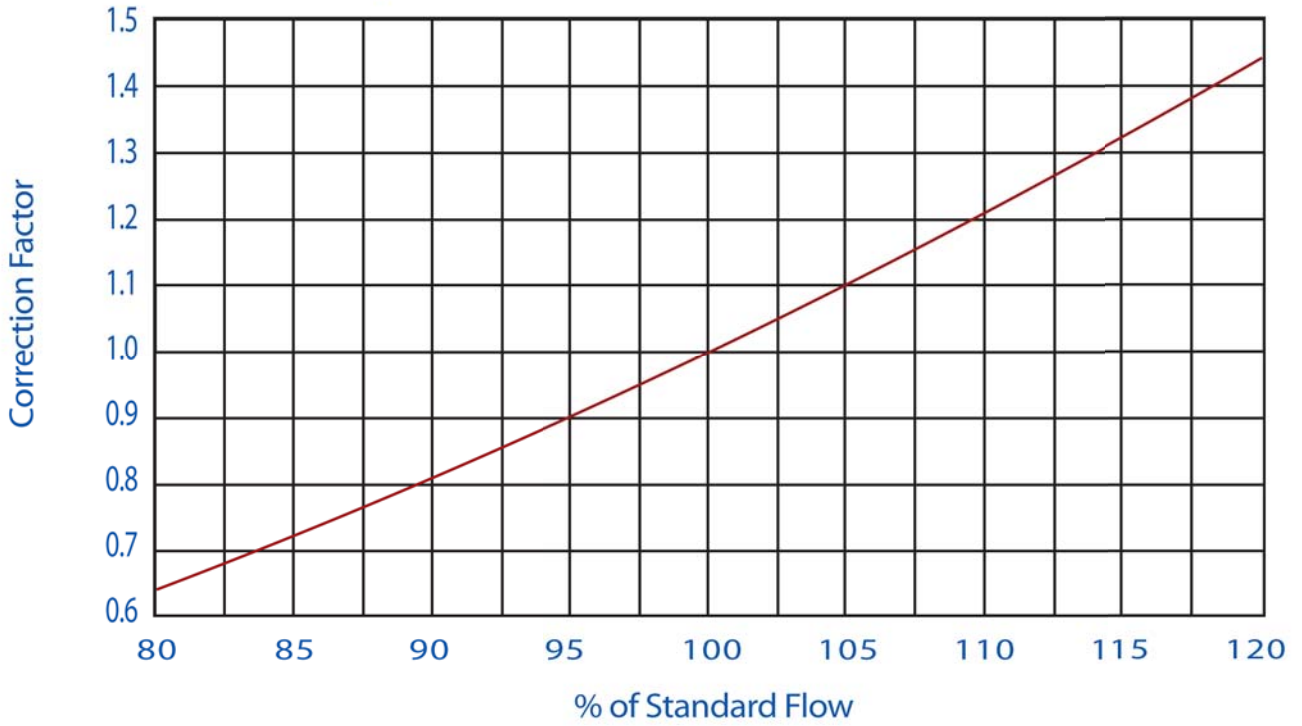

N	1	2	3	4	5	6	7	8	9	10	11	12	13	14	15
MSRW075	1.00	1.00	1.00	1.00	1.00	1.01	1.01	1.01	1.02	1.02	1.02	1.03	1.03	1.04	1.05

N = Number of module





# Unit Capacity Per Module

## COOLING CAPACITY MSRW075

Condenser Leaving Water Temp. °C	Leaving Chilled Water Temperature °C												R22
	5		6		7		8		10		12		
	CAP	PI	CAP	PI	CAP	PI	CAP	PI	CAP	PI	CAP	PI	
30	<b>69.0</b>	13.8	<b>71.6</b>	13.8	<b>74.1</b>	13.9	<b>76.8</b>	14.0	<b>82.4</b>	14.2	<b>88.2</b>	14.3	
35	<b>66.1</b>	15.0	<b>68.5</b>	15.1	<b>71.0</b>	15.2	<b>73.6</b>	15.3	<b>79.0</b>	15.4	<b>84.6</b>	15.6	
37	<b>64.9</b>	15.6	<b>67.2</b>	15.6	<b>69.7</b>	15.8	<b>72.3</b>	15.8	<b>77.5</b>	16.0	<b>83.1</b>	16.2	
40	<b>62.9</b>	16.4	<b>65.3</b>	16.5	<b>67.7</b>	16.6	<b>70.1</b>	16.8	<b>75.3</b>	16.9	<b>80.8</b>	17.0	
45	<b>59.6</b>	18.0	<b>62.0</b>	18.1	<b>64.1</b>	18.2	<b>66.5</b>	18.3	<b>71.5</b>	18.4	<b>76.8</b>	18.6	

Condenser Leaving Water Temp. °C	Leaving Chilled Water Temperature °C												R407c
	5		6		7		8		10		12		
	CAP	PI	CAP	PI	CAP	PI	CAP	PI	CAP	PI	CAP	PI	
30	<b>67.7</b>	14.2	<b>70.5</b>	14.2	<b>73.4</b>	14.2	<b>76.2</b>	14.2	<b>82.2</b>	14.2	<b>88.7</b>	14.3	
35	<b>64.2</b>	15.8	<b>66.9</b>	15.8	<b>69.5</b>	15.8	<b>72.3</b>	15.9	<b>78.1</b>	15.9	<b>84.3</b>	15.9	
37	<b>62.7</b>	16.5	<b>65.3</b>	16.6	<b>68.0</b>	16.6	<b>70.7</b>	16.6	<b>76.4</b>	16.6	<b>82.5</b>	16.6	
40	<b>61.2</b>	17.7	<b>63.0</b>	17.7	<b>65.6</b>	17.7	<b>68.2</b>	17.7	<b>73.8</b>	17.7	<b>79.6</b>	17.8	
45	<b>56.7</b>	19.8	<b>59.0</b>	19.9	<b>61.4</b>	19.9	<b>64.0</b>	19.9	<b>69.2</b>	19.9	<b>74.8</b>	19.9	

Condenser Leaving Water Temp. °C	Leaving Chilled Water Temperature °C												R134a
	5		6		7		8		10		12		
	CAP	PI	CAP	PI	CAP	PI	CAP	PI	CAP	PI	CAP	PI	
30	<b>46.0</b>	10.0	<b>48.1</b>	10.0	<b>50.1</b>	10.0	<b>52.3</b>	10.0	<b>56.8</b>	10.1	<b>61.5</b>	10.0	
35	<b>43.4</b>	11.2	<b>45.3</b>	11.2	<b>47.3</b>	11.2	<b>49.3</b>	11.2	<b>53.6</b>	11.2	<b>58.2</b>	11.2	
37	<b>42.3</b>	11.7	<b>44.3</b>	11.7	<b>46.2</b>	11.7	<b>48.2</b>	11.7	<b>52.4</b>	11.7	<b>56.8</b>	11.7	
40	<b>40.8</b>	12.5	<b>42.7</b>	12.5	<b>44.5</b>	12.5	<b>46.4</b>	12.5	<b>50.4</b>	12.5	<b>54.7</b>	12.5	
45	<b>38.3</b>	13.9	<b>40.0</b>	13.9	<b>41.8</b>	13.9	<b>43.5</b>	13.9	<b>45.3</b>	13.9	<b>51.4</b>	13.9	

CAP Cooling Capacity (kW)

PI Compressor Power input (kW)

Note:

- This table is based on a 5°K difference in water temperature.
- Please contact your local Multistack Agent if you require performance data beyond the limits of the above table.
- Interpolation is permissible. Do not extrapolate.

# Chiller Selection

Select Water-cooled chiller to meet the following requirements:

1. Entering Chilled Water temperature (ECHW).....12.5°C
2. Leaving Chilled Water temperature (LCHW)..... 7°C
3. Chilled Water Flow (CHWF)..... 40.28 l/s
4. Leaving condenser water Temperature..... 32.0°C
5. Entering condenser Water temperature ..... 37.0°C
6. Refrigerant..... R22
7. Power.....AC380V±10%/ 50Hz/ 3phz

## Calculation

1. Determine cooling capacity required (kW)

$$\begin{aligned} \text{Cooling Capacity} &= \text{CHWF} \times 4.187 \times (\text{ECHW} - \text{LCHW}) \\ &= 40.28 \times 4.187 \times (12.5 - 7) \\ &= 928 \text{ kW required} \end{aligned}$$

2. From capacity chart above,

- 1 module at stated conditions will achieve;  
Cooling CAP= 71 kW per MSRW 075 module

Divide the required capacity by achieved capacity at specified conditions to determine required number of modules:

$$= 928 \text{ kW required} = 13.1 \text{ modules}$$

Select 13 modules of MSRW075

$$\text{Capacity of 13 modules} = 6 \times 288 = 1728 \text{ kW}$$

3. To establish Water Flow per module, divided new CHWF by number of modules:

$$\begin{aligned} \text{(1) Nominal Water flow} &= 13 \times 3.5 \\ &= 45.5 \text{ l/s} \end{aligned}$$

Chilled Water Pressure Drop for nominal water flow per module is 35kPa

$$\begin{aligned} \text{(2) Actual water pressure drop} &= 40.28 \div 45.5 = 88.5\% \end{aligned}$$

Use the chart "Pressure Drop Correction Factor for chilled and condenser water Circuit", 13 modules of MSRW075 the correction  $\xi$  is 0.77 for 88% of water flow.

Use the table « Pressure drop correction factor: k »,  $k=1.03$  for the configuration: 13 modules of MSRW075

Actual condenser water pressure drop is:

$$0.77 \times 35 \times 1.03 = 28 \text{ kPa}$$

4. Condenser water flow and pressure drop calculation:

$$\begin{aligned} \text{(1) Condenser water flow} &= 13 \times 4.2 \\ &= 54.6 \text{ L/s} \\ &= 197 \text{ m}^3/\text{h} \end{aligned}$$

- (2) Condenser water pressure drop

Condenser water pressure drop for nominal water flow per module is 35kPa

Use the table «Pressure drop correction factor: k » print at page 9,  $k=1.03$  for the configuration:13 modules of MSRW075.

Actual condenser water pressure drop is:

$$35 \times 1.03 = 36.05 \text{ kPa}$$

(Contact Multistack if lower flow rate is required.)

# Field Wiring Diagram

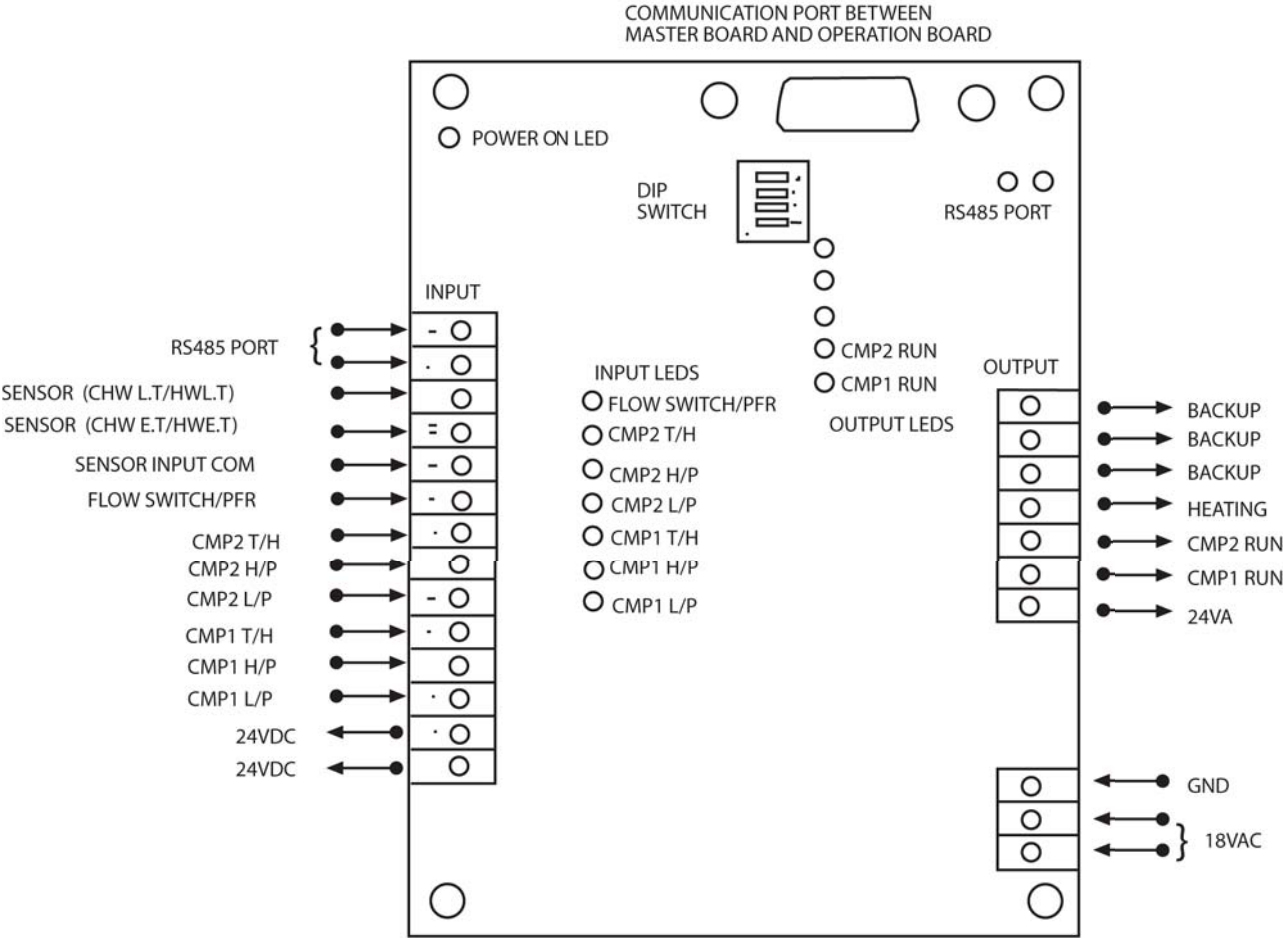
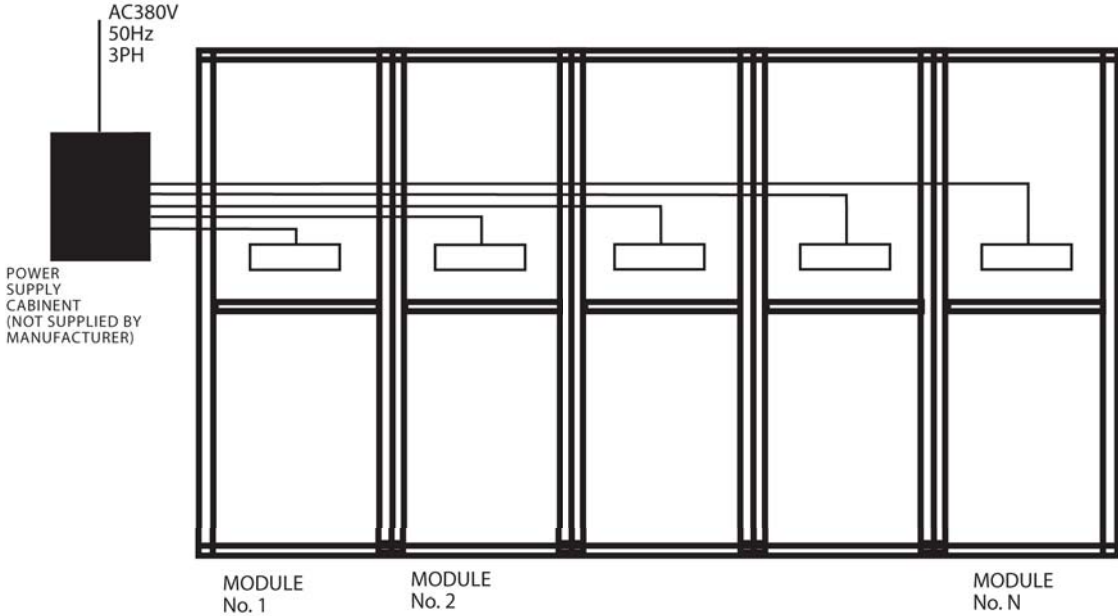

# Chilled Water Piping Line Installation

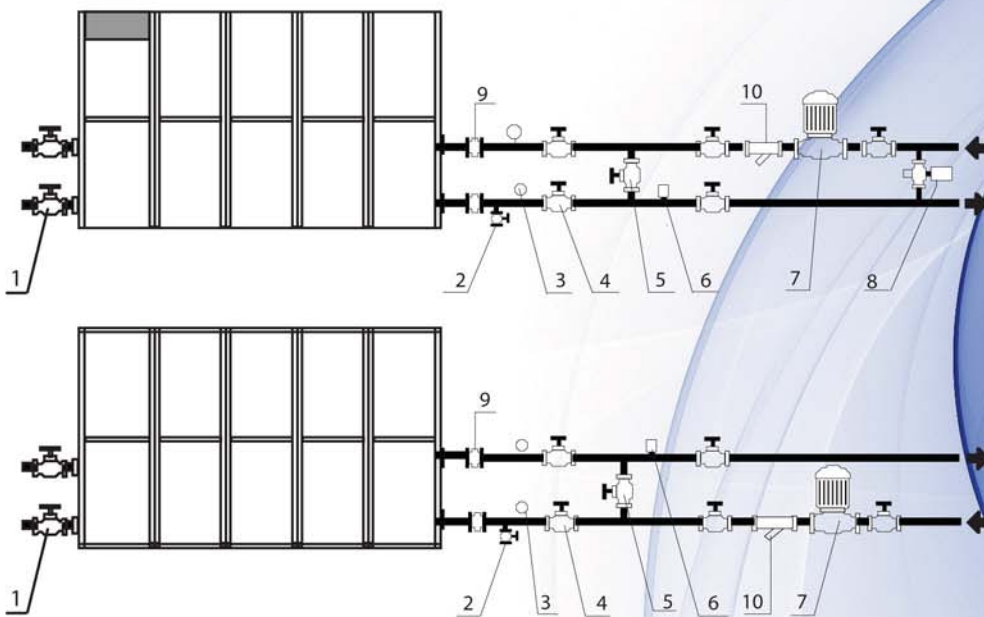

## Condenser Water Piping parts:

1. Drain Valve
2. Drain Valve (1 inch)
3. Pressure Gauge
4. Isolation Gate Valve
5. Back Flush by-pass Valve
6. Water Flow Switch
7. Water Pump
8. Load side differential pressure by-pass Valve
9. Vibration Eliminator
10. Water Strainer

1. It is the customer's responsibility to supply all piping parts, except for those supplied with the chiller.
2. The condenser water by-pass proportion regulating valve will not be necessary if the cooling tower fan is controlled by the condenser water leaving temperature.
3. The condenser water can be controlled by the cooling tower fan or condenser water by-pass, its leaving temperature shouldn't exceed 25% to prevent the compressor from operating at low suction pressure.
4. During the whole installation process, the isolation gate valves on both entering / leaving line to the chiller should be closed. The valves will remain closed until the piping installation; leakage check and cleaning are all completed.
5. To prevent stress on the headers and Victaulic couplings all water pipe work must be properly supported.
6. To prevent water accumulation inside the sensor socket grease should be filled in the sensor socket before inserting the chilled water temperature sensor.

# Low temperature Cooling

MSRW MINI series modular scroll chiller can work at low temperatures (under -10°C leaving water temperature). Suitable for ice-making operations, or technique process control for industry production. When operating at low temperatures, it is recommended to use glycol or other solutions with low freezing points to carry refrigerant, do not use brine or solutions which will rust copper or stainless steel and thus damage the plate heat exchanger. For low temperature applications, it is necessary to correct the chiller's cooling capacity, running power input and HX water pressure drop.

(1)Actual cooling capacity  
= Nominal cooling capacity x C1 x C2  
(2)Actual running power input  
= Nominal running power input x C3 x C4

(3)Actual evaporator water pressure drop  
= Water pressure drop of solution  
0% concentration x C5

## Glycol Concentration Table

Weight Concentration %	0	5	10	15	20	25	30	35
Freezing point temperature oC	0	-1.4	-3.2	-5.4	-7.8	-10.7	-14.1	-17.9
Maximum working temperature oC	5.0	4.0	2.0	0.0	-2.0	-5.0	-8.0	-12.0
Cooling performance correction factor C1	1.000	0.997	0.992	0.988	0.985	0.982	0.980	0.978
Running power correction factor C3	1.000	0.999	0.997	0.996	0.995	0.994	0.993	0.993
Evaporator water pressure drop correction C5 factor C5	1.00	1.050	1.102	1.220	1.305	1.423	1.536	1.740

## Cooling Performance Correction Factor C2 & Running Power Correction

Condensor Leaving Water Temperature °C	Leaving Chilled Water Temperature °C							
	-10	-8	-6	-4	-2	0	2	4
Cooling Performance Correction Factor								
30	0.521	0.566	0.614	0.663	0.726	0.794	0.883	0.962
35	0.484	0.531	0.580	0.632	0.688	0.732	0.861	0.916
40	0.462	0.505	0.553	0.607	0.658	0.714	0.791	0.869
45	0.433	0.480	0.528	0.577	0.624	0.672	0.732	0.822
Running Power Correction Factor C4								
30	0.727	0.754	0.781	0.805	0.833	0.852	0.876	0.902
35	0.778	0.805	0.831	0.858	0.884	0.903	0.932	0.992
40	0.820	0.851	0.892	0.923	0.954	0.987	1.107	1.112
45	0.866	0.879	0.936	0.980	1.011	1.196	1.204	1.231

# Physical Dimensions

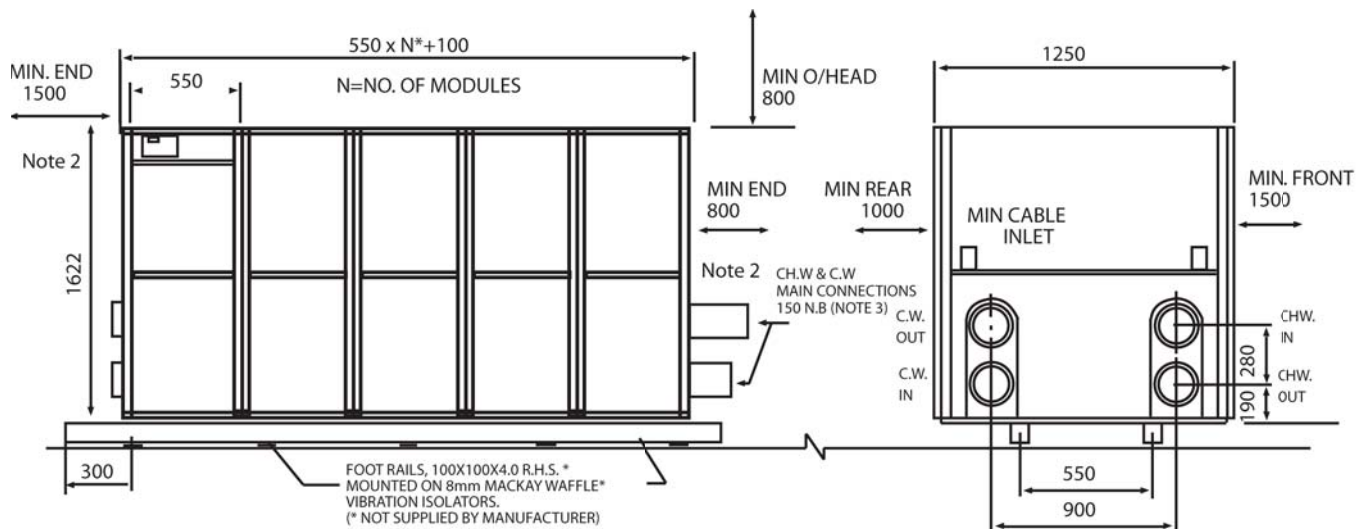

## Notes:

1. Installations must include the following:

- 3/8" BSP socket in all water connections adjacent to chiller for Multistack sensor installation. (Supplied by Multistack)
- Cooling tower by-pass control or other system to prevent over condensing.
- Pressure Tappings for Flow measurement (supplied by Multistack)
- 60 Mesh stainless strainers in water inlet piping.

2. Electrical mains entry may be made from either end of unit. Some larger machines (determined by the current draw & cable size) require mains entry at both ends. Refer to electrical installation data for isolation information and determination.

3. Chilled and condenser water connections may be interchanged end for end as required.

# Electrical Data Per Module

Model		MSRW075		
Refrigerant		R22	R407c	R134a
Power		AC 380 ± 10% V / 50Hz / 3Ph		
Compressor (Each)	MRC (A)	26	29	29
	RLA (A)	19.3	22.9	22.9
	LRA (A)	147	145	145
MSC		(2xN-1) x MRC + LRA		



MULTISTACK INTERNATIONAL LIMITED

140 BERNARD STREET, CHELTENHAM, VICTORIA 3192, AUSTRALIA

TELEPHONE: 61 3 8586 8200 FACSIMILE 61 3 8586 8201

Email: [multistack.sales@dunnair.com](mailto:multistack.sales@dunnair.com)

Web site: [www.multistack.com.au](http://www.multistack.com.au)